

DMX - DMAX diaphragm valve technical description

Made entirely of 316L stainless steel,
the DEFINOX DMX - DMAX diaphragm valve is designed for retention-free flow and a full bore to keep pressure loss to a minimum. A NC (Normally Closed) or NO (Normally Open) air-operated version or a manual version with an ergonomic handle can easily be obtained from the same body and diaphragm.



Design

The DMX - DMAX diaphragm valve consists mainly of three subassemblies:

- **The body**

The solid body, machined from a rolled bar of 316L, guarantees no inclusions and good metallurgical quality. What's more, due to the choice of materials, retort sterilisation is possible up to 140°C.

Various finishes are available on these valves:

- Ra 0,8 µm (180 grit).
- Ra 0,4 µm (240 grit) by mechanical or electro-polishing.
- Ra 0,2 µm (320 grit) by mechanical or electro-polishing.

The operating device is clamp-mounted onto the body allowing the assembly to be quickly dismantled and providing even pressure on the diaphragm.

- **The diaphragm**

It is equipped with a PTFE diaphragm totally inert to cleaning

agents (CIP), solvents, essential oils, etc. It can also be fitted with an EPDM or silicone diaphragm.

The diaphragm is sandwiched between the body and the operating device and a metal core dilates it to the required position between fully open and fully closed.

The valve is equipped with a leak detector in case of diaphragm failure.

- **Operating device**

With the same body and diaphragm, a pneumatic version or a manual version with an ergonomic handle can easily be obtained.

The automatic version can be used with a NO (Normally Open) or NC (Normally Closed) configuration by applying a return spring.

DMX - DMAX diaphragm valve technical description

DMX - DMAX diaphragm valve features

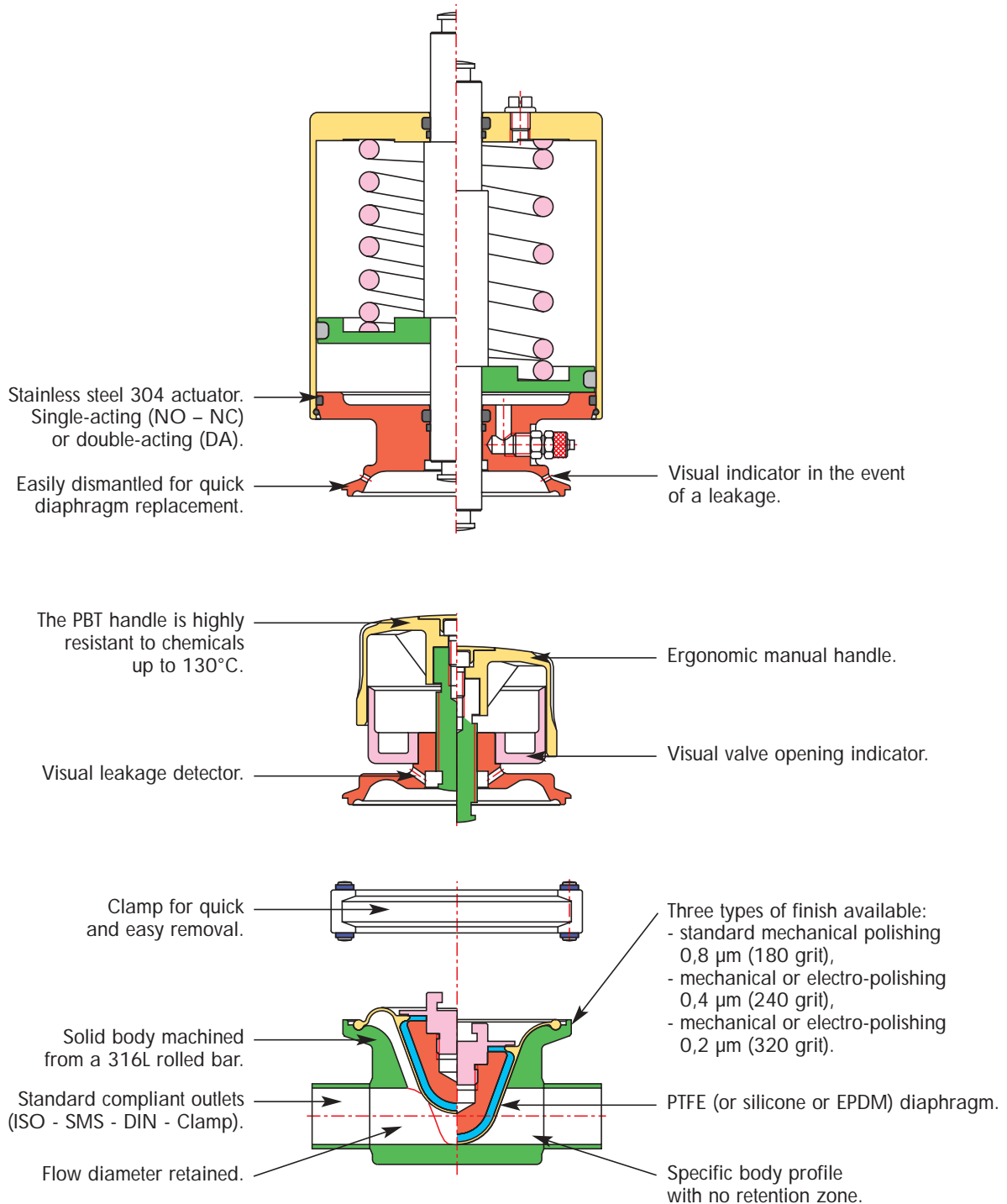

Manual DMX - automated DMAX diaphragm valve dimensions

Manual DMX diaphragm valve

The manual operating device consists of an ergonomic plastic handle that opens and closes the valve smoothly and progressively by means of a screw system. This device incorporates an opening indicator and side leakage

indicator in the event of diaphragm rupture. It is clamped onto the valve body.

The device can be fitted with a stainless steel handle as an option.

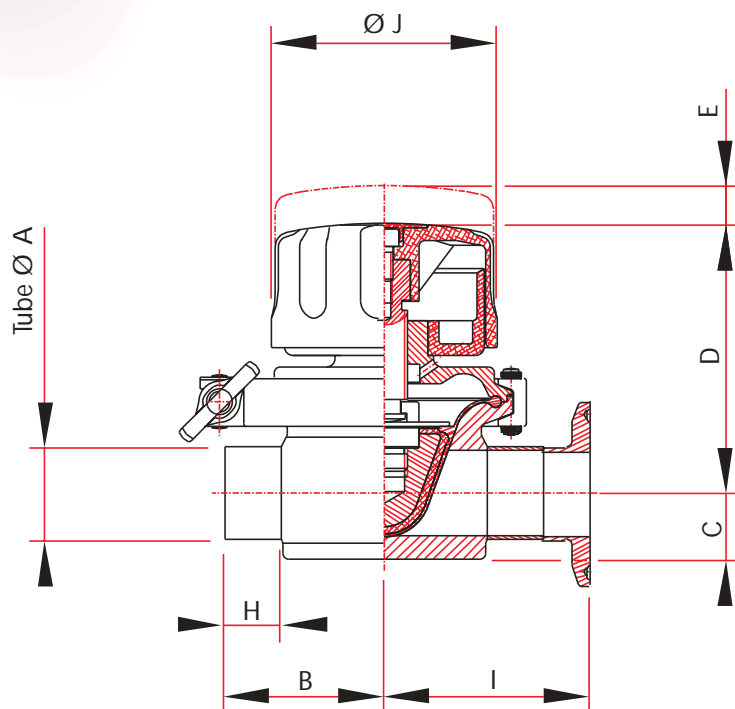

Manual DMX - automated DMAX diaphragm valve dimensions

Manual DMX diaphragm valve

DN		Tube Ø A	B	C	D	E	H	I	Ø J	Weight in kg
SMS	25	25 x 1,2	60	16	97	13	26	72,5	78	2,4
	32	32 x 1	60	23	94	12	25	72,5	78	2,2
	38	38 x 1,2	88,5	25	120	22	41	101	78	4,8
	51	51 x 1,25	88,5	32	114	22	41	101	78	4,9
DIN	10	12 x 1	30	12	56	5	18	42,5	50	0,2
	15	18 x 1	50	14	68	11	29	62,5	50	0,6
	25	28 x 1	60	17	95	12	26	72,5	78	2,4
	32	34 x 1	88,5	20	122	22	43	101	78	2,7
	40	40 x 1	88,5	24	120	22	43	101	78	4,5
US	50	53 x 1,5	88,5	32	114	22	42	101	78	4,8
	1/2"	12,7 x 1,65	30	8	56	6	18	42,5	50	0,16
	3/4"	19,05 x 1,65	50	12	68	10	29	62,5	50	1
	1"	25,4 x 1,65	60	16	98	12	27	72,5	78	1,4
	1"1/2	38,1 x 1,65	88,5	23	121	22	43	101	78	3,3
STANDARD ISO	2"	50,8 x 1,65	88,5	31	114	22	41	101	78	4,9
	13,5	13,5 x 2,25	30	8	56	5	18	42,5	50	0,3
	17,2	17,2 x 2,35	50	10	69	10	29	62,5	50	1
	21,3	21,3 x 2,65	50	12	68	10	30	62,5	50	1
	26,9	26,9 x 2,65	60	16	98	12	26	72,5	78	2,4
	33,7	33,7 x 3,25	60	19	95	12	26	72,5	78	2,5
FOOD ISO	42,4	42,4 x 3,25	88,5	24	120	22	43	101	78	4
	48,3	48,3 x 3,25	88,5	27	117	22	42	101	78	4
	12	12 x 1	30	12	56	5	18	42,5	50	0,2
	17,2	17,2 x 0,85	50	12	68	10	29	62,5	50	1
	21,3	21,3 x 1	50	12	66	10	27	62,5	50	1,1
	25	25 x 1,2	60	16	97	12	26	72,5	78	2,4
	33,7	33,7 x 1,2	88,5	20	122	22	26	101	78	2
	38	38 x 1,2	88,5	25	120	22	41	101	78	4,8
CHEMICAL ISO	40	40 x 1,2	88,5	24	119	22	43	101	78	4,5
	51	51 x 1,2	88,5	30	114	22	41	101	78	4,9
	21,3	21,3 x 2,11	50	12	68	10	29	62,5	50	1
	33,7	33,7 x 2	60	19	94	12	26	72,5	78	2,3
CHEMICAL ISO	42,4	42,4 x 2	88,5	24	120	22	43	101	78	4,1
	48,3	48,3 x 2	88,5	29	118	22	42	101	78	4,2

Manual DMX - automated DMAX diaphragm valve dimensions

Automated DMAX diaphragm valve

In the automatic version, a reversible pneumatic actuator, fastened in the same way as the manual control device, drives the diaphragm to the required position (NC Normally Closed or NO Normally Open).

The actuator is supplied with dry, filtered air at 4,5 minimum to 8 bar maximum pressure. The actuator air fittings are designed for coupling to 4/6 diameter hoses.

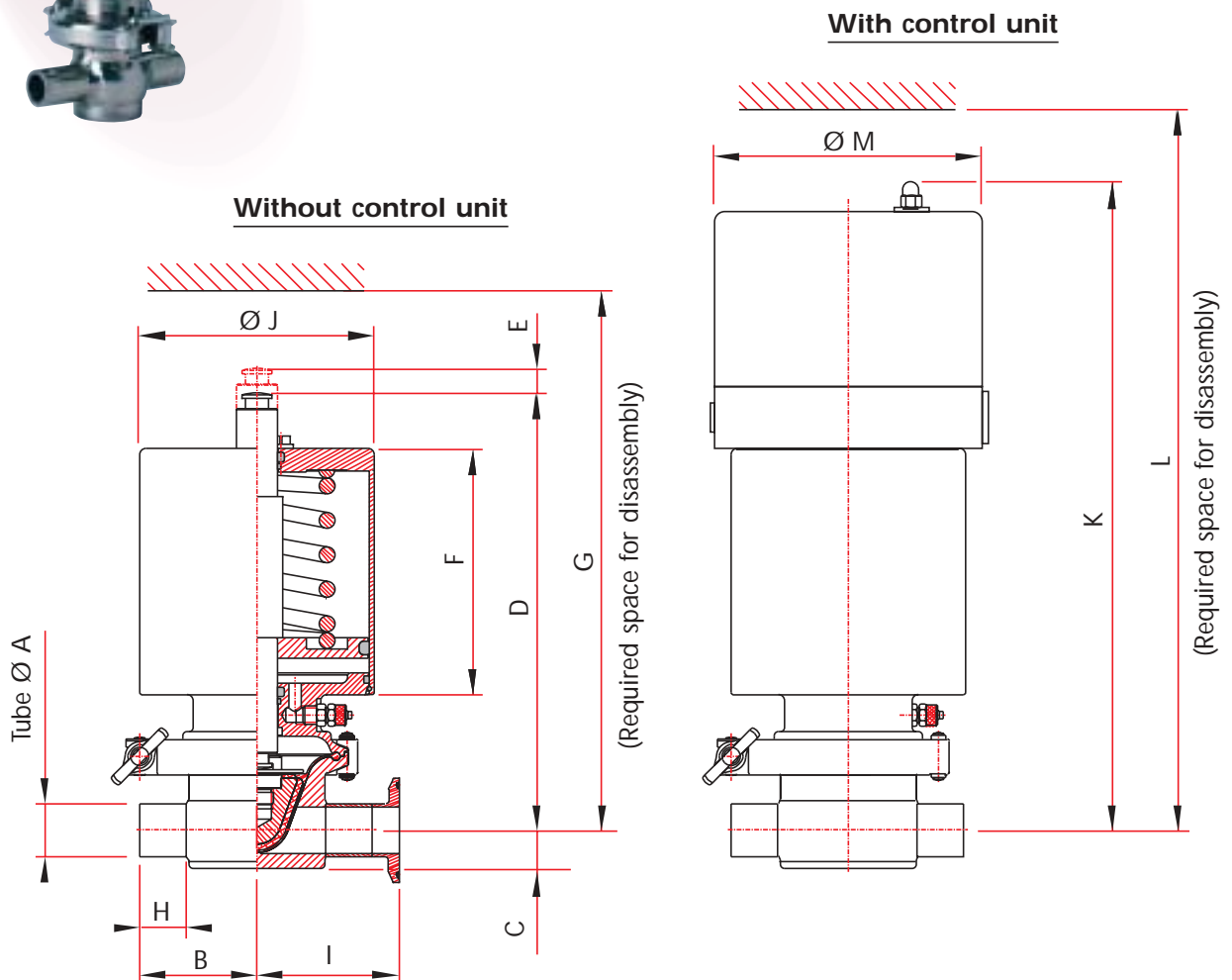

Manual DMX - automated DMAX diaphragm valve dimensions

Automated DMAX diaphragm valve

DN	Tube Ø A	B	C	D	Stroke E	F	G	H	I	Ø J	Weight in kg*	K	L	Ø M
25	25 x 1,2	60	16	224	12	120	262	26	72,5	114	7	314	352	130
32	32 x 1	60	23	220	12	120	255	25	72,5	114	5,8	311	346	130
38	38 x 1,2	88,5	25	284	22	147	340	41	101	159	16,1	365	421	130
51	51 x 1,25	88,5	32	277	22	147	326	41	101	159	16,2	358	407	130
10	12 x 1	30	12	173	5	90	190	18	42,5	59	2,4	268	285	104
15	18 x 1	50	14	181	11	90	211	29	62,5	89	2,7	279	309	104
25	28 x 1	60	17	222	12	120	258	26	72,5	114	7	313	349	130
32	34 x 1	88,5	20	285	22	147	342	43	101	159	14	366	423	130
40	40 x 1	88,5	24	282	22	147	336	43	101	159	15,8	363	417	130
50	53 x 1,5	88,5	32	276	22	147	324	42	101	159	16	357	405	130
1/2"	12,7 x 1,65	30	8	173	5	90	190	18	42,5	59	2,4	268	285	104
3/4"	19,05 x 1,65	50	12	185	11	90	214	29	62,5	89	3,1	279	308	104
1"	25,4 x 1,65	60	16	224	12	120	262	27	72,5	114	6	315	353	130
1"1/2	38,1 x 1,65	88,5	23	284	22	147	340	43	101	159	14,6	365	421	130
2"	50,8 x 1,65	88,5	31	278	22	147	328	41	101	159	16,2	359	409	130
13,5	13,5 x 2,25	30	8	173	5	90	191	18	42,5	59	2,5	268	286	104
17,2	17,2 x 2,35	50	10	182	11	90	212	29	62,5	89	3,2	280	310	104
21,3	21,3 x 2,65	50	12	181	11	90	210	30	62,5	89	3,2	279	308	104
26,9	26,9 x 2,65	60	16	224	12	120	263	26	72,5	114	7	315	354	130
33,7	33,7 x 3,25	60	19	222	12	120	257	26	72,5	114	7,2	313	348	130
42,4	42,4 x 3,25	88,5	24	274	22	147	327	43	101	159	13,3	364	419	130
48,3	48,3 x 3,25	88,5	27	271	22	147	320	42	101	159	13,3	361	413	130
12	12 x 1	30	12	173	5	90	190	18	42,5	59	2,4	268	285	104
17,2	17,2 x 0,85	50	12	181	11	90	210	29	62,5	89	3,1	279	308	104
21,3	21,3 x 1	50	12	180	11	90	208	27	62,5	89	2,8	277	305	104
25	25 x 1,2	60	16	224	12	120	262	26	72,5	114	7	314	352	130
33,7	33,7 x 1,2	88,5	20	285	22	147	342	26	101	159	13,3	366	423	130
38	38 x 1,2	88,5	25	284	22	147	340	41	101	159	16,1	364	420	130
40	40 x 1,2	88,5	24	283	22	147	338	43	101	159	15,9	363	418	130
51	51 x 1,2	88,5	30	277	22	147	326	41	101	159	16,2	358	407	130
21,3	21,3 x 2,11	50	12	181	11	90	210	29	62,5	89	3,2	279	308	104
33,7	33,7 x 2	60	19	220	12	120	255	26	72,5	114	7,1	311	346	130
42,4	42,4 x 2	88,5	24	283	22	147	338	43	101	159	13,2	364	419	130
48,3	48,3 x 2	88,5	29	279	22	147	330	42	101	159	13,2	360	411	130

* Without control unit

Manual DMX - automated DMAX diaphragm valve working conditions

Manual DMX diaphragm valve elastomer diaphragm

DN		Pressure drop (Kv)	Pressure drop (Cv)	Sealing pressure (Bar)
SMS	25	47	54,52	12
	32	47	54,52	12
	38	59	68,44	10
	51	59	68,44	10
DIN	10	8	9,28	12
	15	15	17,4	12
	25	47	54,52	12
	32	47	54,52	10
	40	59	68,44	10
	50	59	68,44	10
US	1/2"	8	9,28	12
	3/4"	15	17,4	12
	1"	47	54,52	12
	1"1/2	59	68,44	10
	2"	59	68,44	10
STANDARD ISO	13,5	8	9,28	12
	17,2	8	9,28	12
	21,3	15	17,4	12
	26,9	15	17,4	12
	33,7	47	54,52	10
	42,4	59	68,44	10
	48,3	59	68,44	10
FOOD ISO	12	8	9,28	12
	17,2	15	17,4	12
	21,3	15	17,4	12
	25	47	54,52	12
	33,7	47	54,52	10
	38	59	68,44	10
	40	59	68,44	10
	51	59	68,44	10
CHEMICAL ISO	21,3	15	17,4	12
	33,7	47	54,52	10
	42,4	59	68,44	10
	48,3	59	68,44	10

FOR ALL DIAMETERS OF THE DMX VALVE WITH ELASTOMER DIAPHRAGM		
Maximum temperature: +140 °C	Minimum temperature: 0 °C	Temperature difference: 100 °C
Maximum working pressure: 10 Bar	Vacuum resistance: 10 ⁻⁶ mbar	Diaphragm life: 100 000
Sealing under helium (leakage rate): 10 ⁻⁶ atm.cm ³ /s		

Manual DMX - automated DMAX diaphragm valve working conditions

Manual DMX diaphragm valve PTFE diaphragm

DN		Pressure drop (Kv)	Pressure drop (Cv)	Sealing pressure (Bar)
SMS	25	47	54,52	12
	32	47	54,52	12
	38	59	68,44	10
	51	59	68,44	10
DIN	10	8	9,28	12
	15	15	17,4	12
	25	47	54,52	12
	32	47	54,52	10
	40	59	68,44	10
	50	59	68,44	10
US	1/2"	8	9,28	12
	3/4"	15	17,4	12
	1"	47	54,52	12
	1"1/2	59	68,44	10
	2"	59	68,44	10
STANDARD ISO	13,5	8	9,28	12
	17,2	8	9,28	12
	21,3	15	17,4	12
	26,9	15	17,4	12
	33,7	47	54,52	10
	42,4	59	68,44	10
	48,3	59	68,44	10
FOOD ISO	12	8	9,28	12
	17,2	15	17,4	12
	21,3	15	17,4	12
	25	47	54,52	12
	33,7	47	54,52	10
	38	59	68,44	10
	40	59	68,44	10
	51	59	68,44	10
CHEMICAL ISO	21,3	15	17,4	12
	33,7	47	54,52	10
	42,4	59	68,44	10
	48,3	59	68,44	10

FOR ALL DIAMETERS OF THE DMX VALVE WITH PTFE DIAPHRAGM		
Maximum temperature: +140 °C	Minimum temperature: 0 °C	Temperature difference: 100 °C
Maximum working pressure: 8 Bar	Vacuum resistance: 10 ⁻³ mbar	Diaphragm life: 40 000
Sealing under helium (leakage rate): 10 ⁻³ atm.cm ³ /s		

Manual DMX - automated DMAX diaphragm valve working conditions



Automated DMAX diaphragm valve elastomer diaphragm

DN		Pressure drop (Kv)	Pressure drop (Cv)	Sealing pressure (Bar)	Opening time (s)	Air consumption (NI)
SMS	25	47	54,52	12	0,9	1
	32	47	54,52	12	0,9	1
	38	59	68,44	10	3	3
	51	59	68,44	10	3	3
DIN	10	8	9,28	12	0,3	0,5
	15	15	17,4	12	0,6	0,5
	25	47	54,52	12	0,9	1
	32	47	54,52	10	3	3
	40	59	68,44	10	3	3
	50	59	68,44	10	3	3
US	1/2"	8	9,28	12	0,3	0,5
	3/4"	15	17,4	12	0,6	0,5
	1"	47	54,52	12	0,9	1
	1"1/2	59	68,44	10	3	3
	2"	59	68,44	10	3	3
STANDARD ISO	13,5	8	9,28	12	0,3	0,5
	17,2	8	9,28	12	0,6	0,5
	21,3	15	17,4	12	0,6	0,5
	26,9	15	17,4	12	0,9	1
	33,7	47	54,52	10	0,9	1
	42,4	59	68,44	10	3	3
	48,3	59	68,44	10	3	3
FOOD ISO	12	8	9,28	12	0,3	0,5
	17,2	15	17,4	12	0,6	0,5
	21,3	15	17,4	12	0,6	0,5
	25	47	54,52	12	0,9	1
	33,7	47	54,52	10	3	3
	38	59	68,44	10	3	3
	40	59	68,44	10	3	3
	51	59	68,44	10	3	3
CHEMICAL ISO	21,3	15	17,4	12	0,6	0,5
	33,7	47	54,52	10	0,9	1
	42,4	59	68,44	10	3	1,5
	48,3	59	68,44	10	3	1,5

FOR ALL DIAMETERS OF THE DMAX VALVE WITH ELASTOMER DIAPHRAGM		
Maximum temperature: +140 °C	Minimum temperature: 0 °C	Temperature difference: 100 °C
Maximum working pressure: 10 Bar	Vacuum resistance: 10 ⁻⁶ mbar	Diaphragm life: 100 000
Maximum supply pressure: 8 Bar	Minimum supply pressure: 4,5 Bar	Sealing under helium (leakage rate): 10 ⁻⁶ atm.cm ³ /s

Manual DMX - automated DMAX diaphragm valve working conditions

Automated DMAX diaphragm valve PTFE diaphragm

DN		Pressure drop (Kv)	Pressure drop (Cv)	Sealing pressure (Bar)	Opening time (s)	Air consumption (NI)
SMS	25	47	54,52	12	0,9	1
	32	47	54,52	12	0,9	1
	38	59	68,44	10	3	3
	51	59	68,44	10	3	3
DIN	10	8	9,28	12	0,3	0,5
	15	15	17,4	12	0,6	0,5
	25	47	54,52	12	0,9	1
	32	47	54,52	10	3	3
	40	59	68,44	10	3	3
	50	59	68,44	10	3	3
US	1/2"	8	9,28	12	0,3	0,5
	3/4"	15	17,4	12	0,6	0,5
	1"	47	54,52	12	0,9	1
	1"1/2	59	68,44	10	3	3
	2"	59	68,44	10	3	3
STANDARD ISO	13,5	8	9,28	12	0,3	0,5
	17,2	8	9,28	12	0,6	0,5
	21,3	15	17,4	12	0,6	0,5
	26,9	15	17,4	12	0,9	1
	33,7	47	54,52	10	0,9	1
	42,4	59	68,44	10	3	3
	48,3	59	68,44	10	3	3
FOOD ISO	12	8	9,28	12	0,3	0,5
	17,2	15	17,4	12	0,6	0,5
	21,3	15	17,4	12	0,6	0,5
	25	47	54,52	12	0,9	1
	33,7	47	54,52	10	3	3
	38	59	68,44	10	3	3
	40	59	68,44	10	3	3
	51	59	68,44	10	3	3
CHEMICAL ISO	21,3	15	17,4	12	0,6	0,5
	33,7	47	54,52	10	0,9	1
	42,4	59	68,44	10	3	1,5
	48,3	59	68,44	10	3	1,5

FOR ALL DIAMETERS OF THE DMAX VALVE WITH PTFE DIAPHRAGM		
Maximum temperature: +140 °C	Minimum temperature: 0 °C	Temperature difference: 100 °C
Maximum working pressure: 8 Bar	Vacuum resistance: 10 ⁻³ mbar	Diaphragm life: 40 000
Maximum supply pressure: 8 Bar	Minimum supply pressure: 4,5 Bar	Sealing under helium (leakage rate): 10 ⁻³ atm.cm ³ /s

Manual DMX - automated DMAX diaphragm valve working conditions



Diaphragm valve pressure drop

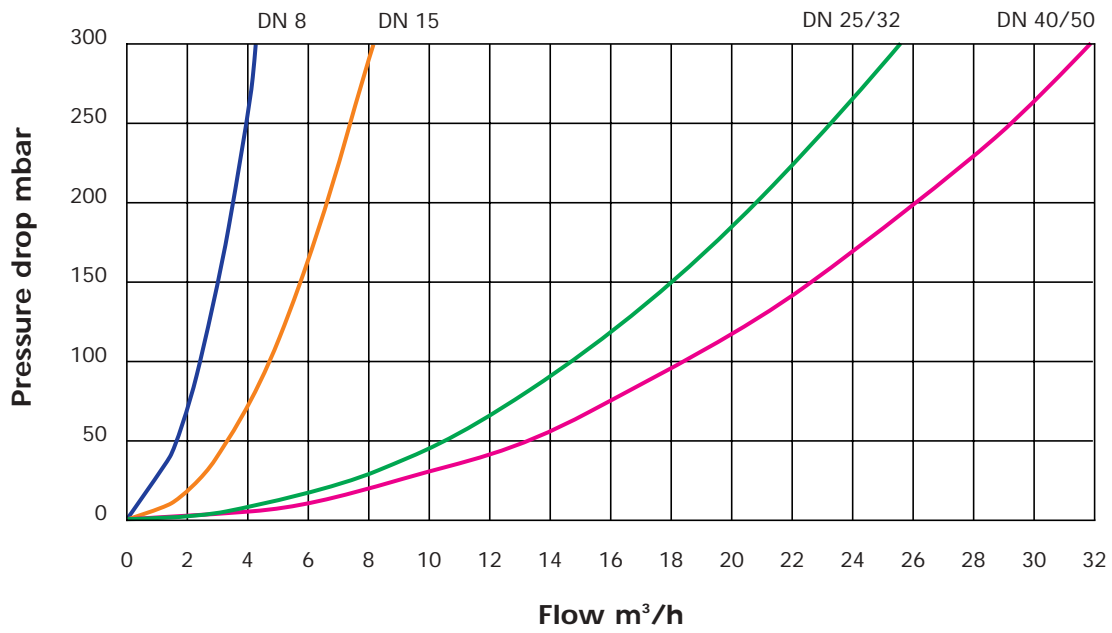

Draw-off diaphragm valve

Design

This valve is optimised for sampling, drainage or bypass purposes. It has been designed to

reduce retention and dead zones in the main line.

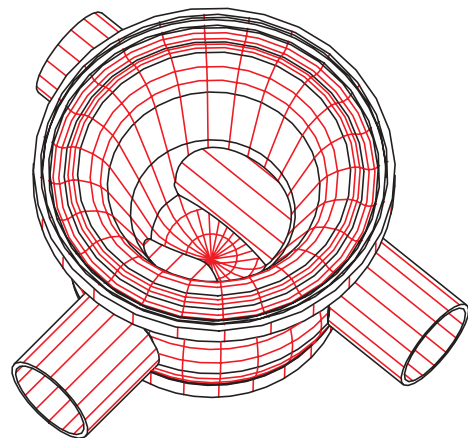
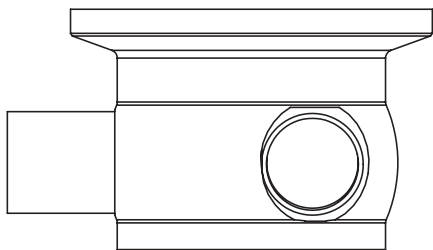
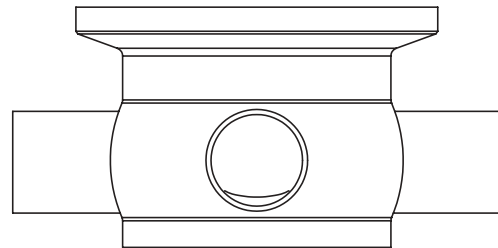
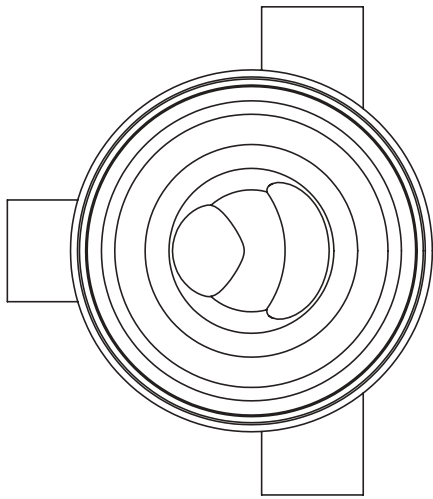

Divert diaphragm valve with T configuration

Design

This valve is designed to eliminate dead zones on the valve outlet. The third T-connected line can be used for draining steam condensates or as a bypass.

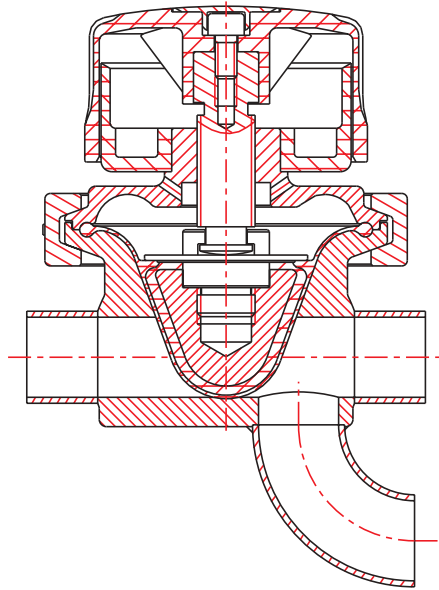

Diaphragm valve with sterilisation connections

Design

The lower line equipped with a valve is used for sampling or draining condensates, as a bypass or for sterilising the outlets.

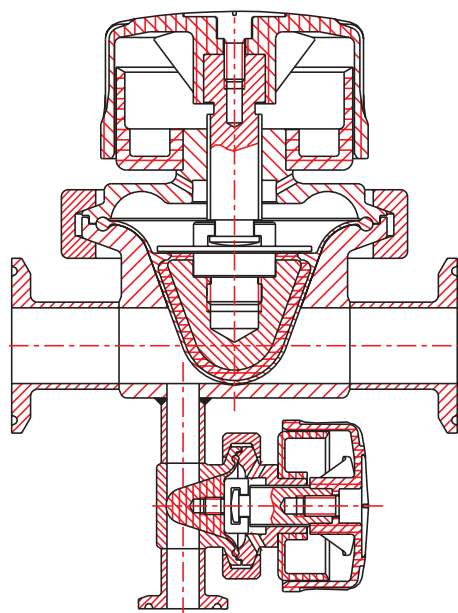

Sampling diaphragm valves

Design

DEFINOX manufactures sampling valves, for welding onto walls, with identical characteristics to the standard diaphragm valve.

An additional port to the sampling port is used for washing and sterilising by circulation through the valve. Manual and automatic versions available.

DMX sampling diaphragm valve

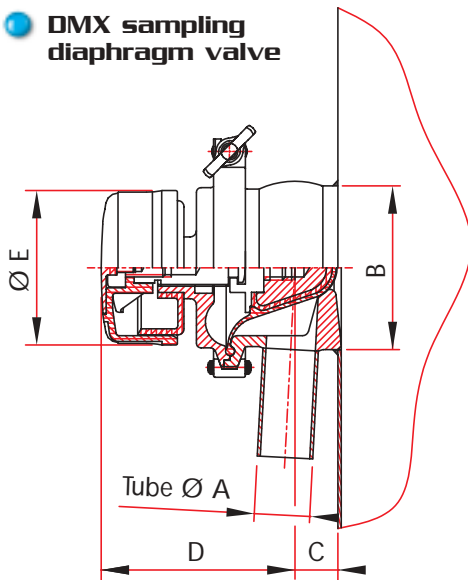

DMAX sampling diaphragm valve

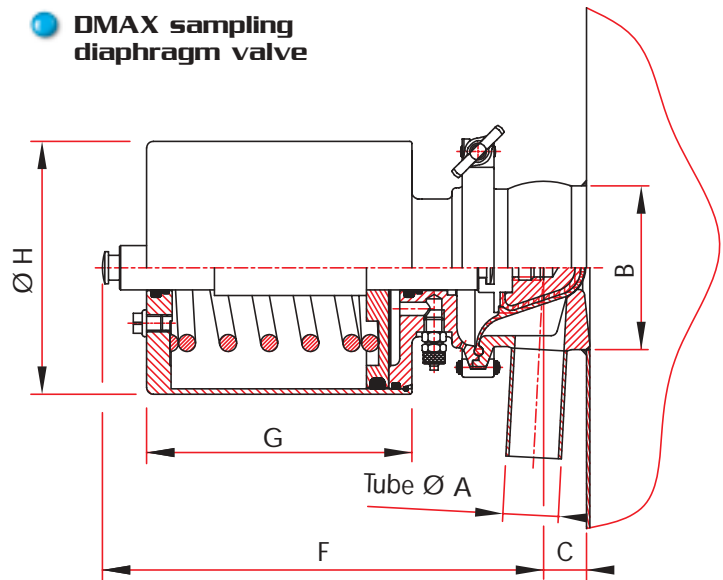

DMX sterilisable sampling diaphragm valve

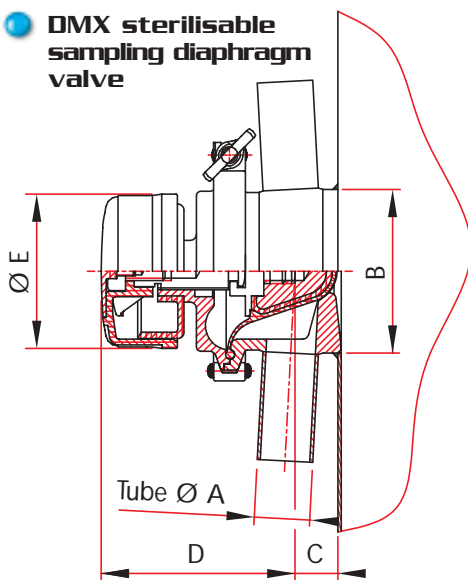

DMAX sterilisable sampling diaphragm valve

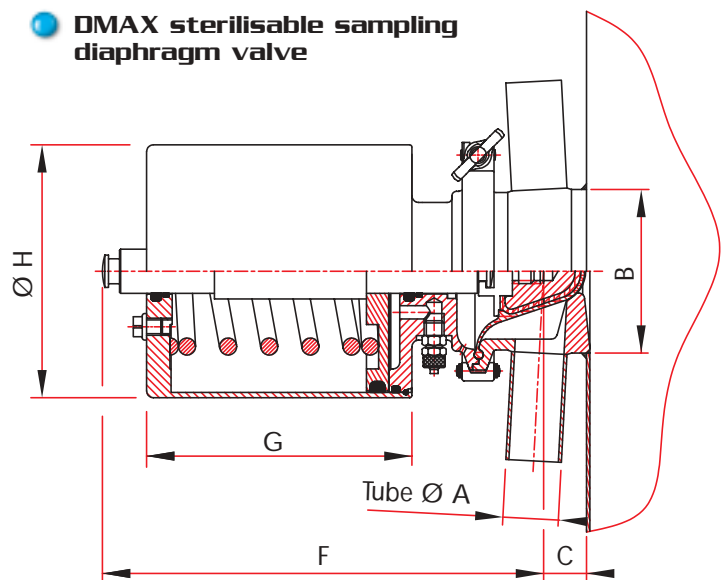

DN	Ø A	B	C	D	Ø E	F	G	Ø H
6/8	8	25	5	56	50	173	90	59
10/12	12	53	8	68	50	181	90	89
9/13,5	13,5	53	8	68	50	181	90	89
16/18	18	53	8	68	50	181	90	89

Sampling diaphragm valves

DMX sampling diaphragm valve flow rate

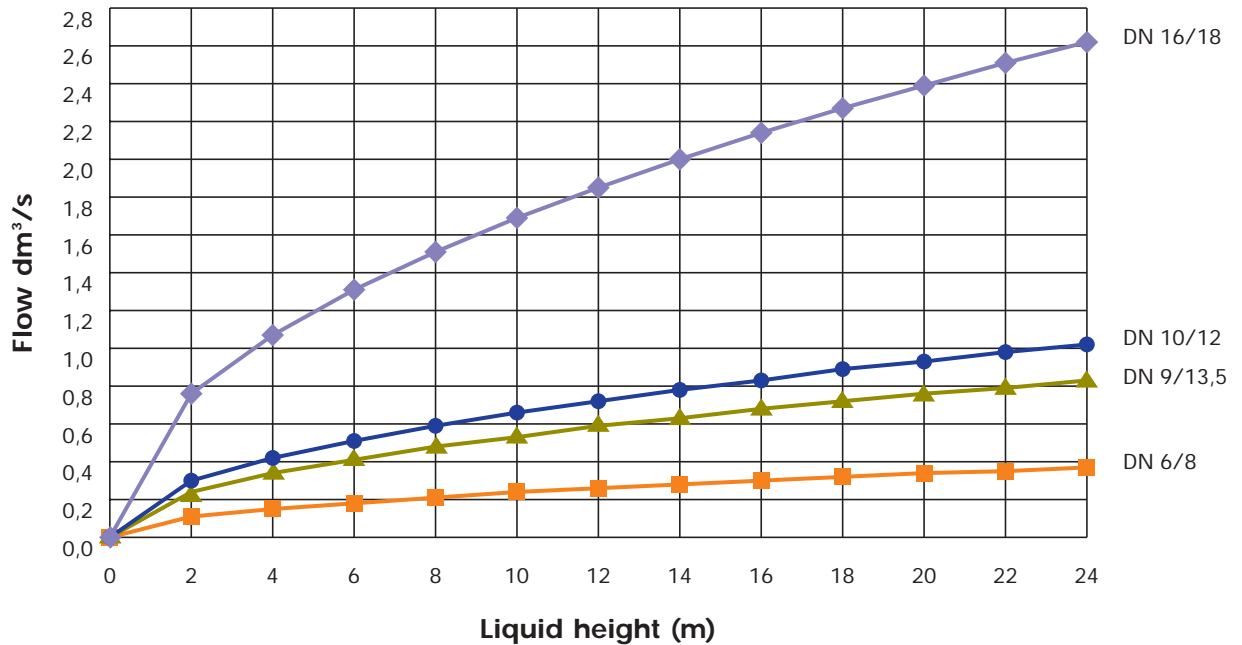

Working conditions

FOR ALL DIAMETERS OF DMX - DMAX SAMPLING DIAPHRAGM VALVES		
Maximum temperature: +140 °C	Maximum working pressure: 8 Bar max. for PTFE diaphragm	Maximum working pressure: 10 Bar for elastomer diaphragm
Actuator supply: Dry filtered air between 4,5 and 8 Bar	Closing time for: DMAX DN 6/8: 0,3 s	Closing time for: DMAX DN 10/12: 0,5 s
PTFE diaphragm longevity: 40 000	Elastomer diaphragm longevity: 100 000	

Standard signal back equipment suitable for the automated DIMAX diaphragm valves

automated DIMAX diaphragm valves DN 25 to 50
(figures 6 - 7 - 8 only for the DN 13 to 21)

Model	Signal back equipment & Fixing device	Components						Remarks
		Switch or Contact		Solenoid valve		Electronic		
		Reference	Characteristics	Reference	Characteristics	Reference	Characteristics	
Bracket	Figure 2 St. St. bracket for M18 switch (M12 on request)	7007906	PNP 10 - 36 V DC		None		None	1 or 2 switch(es) assembled Moulded cable: Lg 6 m
		7007911	20 - 250 V AC/DC					
		7007949 (M12)	PNP 10 - 36 V DC					
Classic control unit	Figure 3 Double St. St. bracket for prismatic switches (40x26x12)	7007922	PNP 10 - 36 V DC		None		None	1 or 2 switch(es) assembled Moulded cable: Lg 2 m
		7007930	20 - 250 V AC/DC					
		7007991	NAMUR					
Classic control unit	Figure 4 Ø130 control unit H: 120 fixed on the actuator st. st. or smoked housing for switches and solenoid valve	7007922	PNP 10 - 36 V DC	7007943	24 V AC/DC 2,5 W		None	1 or 2 switch(es) assembled, as well as 1 solenoid valve 3/2
		7007930	20 - 250 V AC/DC	7007944	48 V AC/DC 2,5 W			
		7007991	NAMUR	7007947	110 V AC 2,5 VA			
Classic control unit	Figure 5 Ø130 control unit H: 120 fixed on the actuator st. st. or smoked housing for contacts and solenoid valve	7007923	Contactor	7007943	24 V AC/DC 2,5 W		None	1 or 2 contact(s) assembled, as well as 1 solenoid valve 3/2
			1 max: 100 mA	7007944	48 V AC/DC 2,5 W			
			20 - 250 V AC/DC	7007947	110 V AC 2,5 VA			
Classic control unit	Figure 6 Ø104 control unit H: 120 fixed on the actuator st. st. housing for switches and solenoid valve	7007922	PNP 10 - 36 V DC	7007943	24 V AC/DC 2,5 W		None	1 or 2 switch(es) assembled, as well as 1 solenoid valve 3/2
		7007930	20 - 250 V AC/DC	7007944	48 V AC/DC 2,5 W			
		7007991	NAMUR	7007947	110 V AC 2,5 VA			
DN 130 control unit AS-i link	Figure 7 Ø104 control unit H: 120 fixed on the actuator st. st. housing for contacts and solenoid valve	7007923	Contactor	7007943	24 V AC/DC 2,5 W		None	1 or 2 contact(s) assembled, as well as 1 solenoid valve 3/2
			1 max: 100 mA	7007944	48 V AC/DC 2,5 W			
			20 - 250 V AC/DC	7007947	110 V AC 2,5 VA			
DN 130 control unit AS-i link	Figure 8 Ø130 control unit H: 110 fixed on the actuator st. st. or smoked housing for switches, 1 solenoid valve & AS-i module	7008045	Prismatic switch	7810504	Pilot & Interface	7707999	AS-i module with link cable and vampire connector	1 or 2 switch(es) assembled and 1 solenoid valve
				7007952		7010015		

Standard signal back equipment suitable for the automated DMAX diaphragm valves

Photos and drawings of the figures mentioned on the data sheet



Fig. 2: St. St. bracket



Fig. 4: Ø 130 control unit



Fig. 6: Ø 104 control unit



Fig. 8 : Ø 130 control unit

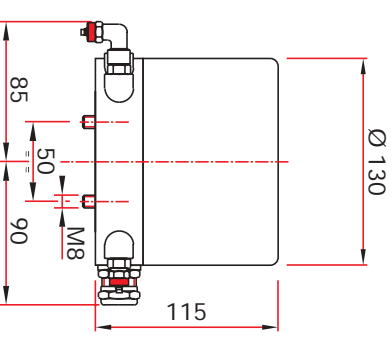

Ø 130 standard control unit smoking housing



Fig. 3: Double st. st. bracket



Fig. 5: Ø 130 control unit



Fig. 7: Ø 104 control unit

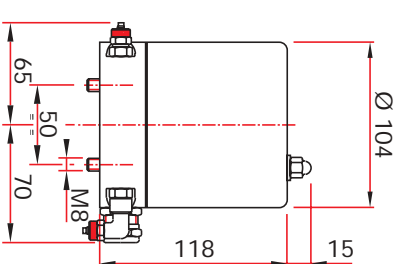

Ø 104 control unit st. st. housing

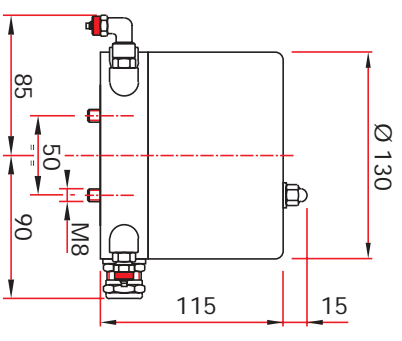

Ø 130 standard control unit st. st. housing

Automated DMAX diaphragm valve signal back equipment

The choice of signal back equipment depends on the functions to be performed.

Remarks regarding the standard signal back equipment

1 - On request, we can fit Eex microcontacts or Namur pneumatic switches in control units for explosive environments.

2 - Specific detection devices can be studied (lantern detection).

3 - The supply of a control unit includes the entry gland, wiring to the electric components terminal strip and the 4/6 pneumatic hose from the unit to the actuator.

4 - Standard signal-back equipment can also be complemented by the following accessories:

- rapid air release
- stainless steel or semi-rigid wiring
- stainless steel air connection
- etc...

Note: The DMX diaphragm valve can not be equipped with signal back equipment, for the moment.

AS-i network

The AS-i network provides a reliable, cost-effective valve networking solution.

An AS-i module installed in each of the signal back units allows the control of all pneumatic functions

on DEFINOX valves (valve opening and closing, stroke of the plugs...) and read the information sent by the opening and closing sensors, via the AS-i network.

Advantages of the AS-i network

- Open standard.
- Quick and easy to install and put into operation.
- Quick to wire up due to the use of "vampire" connectors and a non-shielded two-core cable.
- Free topology.
- Several AS-i masters available (PLC couplers or Profibus-DP, Device-Net, Interbus-S, WorldFip, Modbus, Modbus-Plus or other gateways).
- Max. 62 nodes on AS-i network distributed over 100 m of cable (300 m with repeaters).
- Cycle time: approx. 5ms for 31 nodes and 10 ms for 62 nodes.
- Transmission error control mechanisms.
- Extension possibilities.

